

FM | MAN 51/60G GAS FUEL

POWER RANGE
20,200 kWe

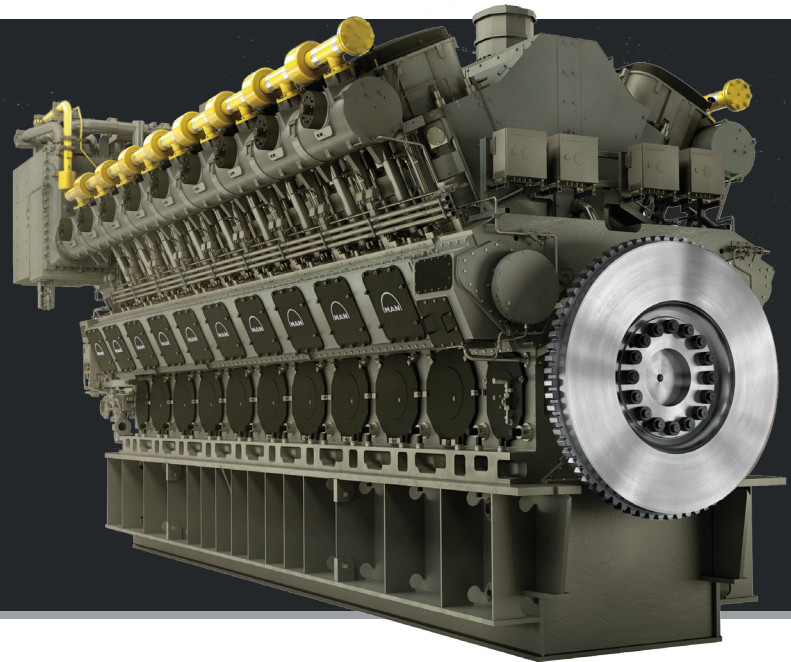

Largest and most powerful of its kind

The FM | MAN 51/60G boasts clean combustion, high efficiency, and comparatively low carbon dioxide emissions, all combined with the lower economics of natural gas. This new class of large-bore engine brings the benefits of gas engines to power and co-generation plants, providing maximum output combined with flexibility and reliability.

APPLICATIONS	INSTALLATIONS	KEY ADVANTAGES
<ul style="list-style-type: none"> Power Generation 	<ul style="list-style-type: none"> Industrial Power Generation Municipalities Universities Schools Hospitals CHP IPP/Utilities Distributed Generation 	<ul style="list-style-type: none"> Largest, most powerful 4-stroke gas engine on the market The highest efficiency in the combustion engine field Reliable combustion of lean air/gas mixtures High and stable ratings in hot climates and at high elevations Excellent load response Low gas-admission pressures

ENGINE SPECIFICATIONS			
Cylinder Configuration	18V	Displacement/Cylinder-L (cu in)	122.6 (7,482)
Cylinder Bore - mm (in)	510 (20)	Mean Piston Speed - m/s (ft/min)	10.3 (33.8) - 514 rpm
Piston Stroke - mm (in)	600 (23.6)	BMEP - bar (psi)	20-21.9 (290-318) - 514 rpm
Cycle	4 Stroke		

FM | MAN 51/60G

POWER RANGE
20,200 kWe

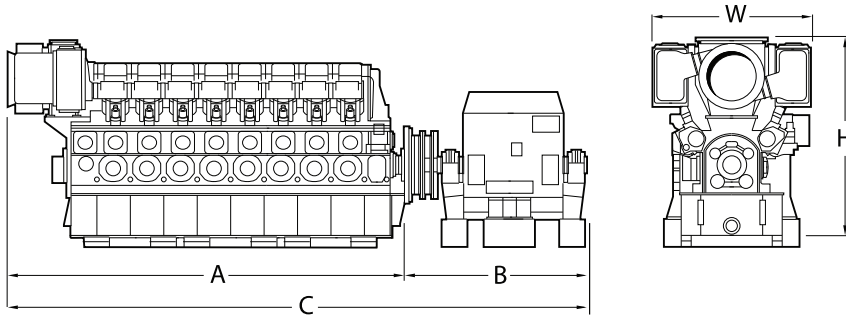
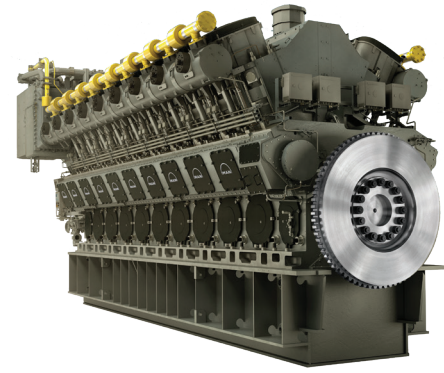

DIMENSIONS

CYLINDERS	A (mm)	B (mm)	C (mm)	W (mm)	H (mm)	DRY WEIGHT TONS (m) (lbs)
18V	13,148	5,410	18,558	4,700	6,530	373 (746,000)

Drawings are for illustration only. For installation obtain certified prints.

POWER RATINGS

CYLINDERS	Aspiration	GENERATOR 514 RPM 60Hz kWe
18V	Turbocharged	20,182 18,427

NOTES

All ratings subject to factory approved application. Generator efficiency 97.6%. Power ratings P_{ISO} are as specified in DIN ISO 3046-1. Power rating valid for tropical conditions: Air temp 45°C. Cooling water temp. at aircooler 52°C. Ambient pr 1 bar.



FAIRBANKS MORSE
AN ENPRO INDUSTRIES COMPANY



701 White Avenue
Beloit, Wisconsin 53511 USA
1-800-356-6955

FM.Marketing@fairbanksmorse.com

©2018 Fairbanks Morse. All rights reserved. Form 3014.0818

fairbanksmorse.com